

SNAP Quadrature Input Module

Features

- 4,000 Vrms optical isolation
- Built-in LED status indicators
- 4 times encoder resolution
- Input signals in 4–24 VDC range

Description

The SNAP-IDC5Q quadrature input module is part of the SNAP PAC System. It mounts on a SNAP PAC rack and is designed to allow a SNAP PAC brain or R-series controller with high-speed counting capability (either a standard wired model or a Wired+Wireless™ model) to resolve two axes of rotating position information from quadrature encoder devices. The module outputs a pulse to the SNAP PAC processor upon each change in quadrature state. The processor counts the module output pulses and keeps track of the direction and position.

The SNAP-IDC5Q can be used with most quadrature devices, including transducers with TTL, CMOS, and open collector outputs. All inputs are isolated from each other and do not share any common connections.

SNAP racks use a retention rail locking system that holds modules securely to the rack. Normally, a hold-down screw is not required. However, for applications that require additional module security, each module has provisions for two 4–40 by ½-inch standard machine screws to hold each module in position on the SNAP rack.

Module Operation

For each axis, the SNAP-IDC5Q quadrature module converts a quadrature signal to a stream of pulses that is sent to the I/O processor on one of two input channels. The rotation direction of the encoder determines which output is used.

One 1.6 microsecond pulse is output for each change of quadrature state. The actual resolution of the position count is four times the encoder resolution (4xPPR).

The position count is incremented when the signal into the A channel leads the signal into the B channel. It is decremented when the signal into the B channel leads the signal into the A channel.

Since the I/O processor (brain or on-the-rack controller) has a maximum input count rate, the maximum allowable RPM at which the encoder may turn is related to the number of cycles per turn that the encoder outputs. See charts on the next two pages.



SNAP-IDC5Q

Notes for legacy hardware: The SNAP-IDC5Q is also compatible with Ethernet-based SNAP-B3000-ENET and SNAP-UP1-ADS brains, as well as B3000, B3000-B, and B3000-HA brains, which use the *mistic* protocol. From a mounting standpoint the module is treated as a standard SNAP I/O digital module, which means it can be installed only in the first eight positions (0–7) of larger SNAP B-series racks.

Specifications

Logic Voltage	5 VDC
Operating Ambient Temperature	0 to 70 °C
Isolation input-to-output	4,000 Vrms
Input Voltage Range	4–24 VDC
Input Resistance	1K ohms @ 4 V 560 ohms @ 24 V
Input Allowed for No Output	1 V
Logic Supply Current @ 5 VDC	120 mA
Maximum Input Frequency, 50% Duty Cycle	25 kHz for SNAP PAC brains and controllers with high-speed digital functions Legacy brains vary*
Maximum Reverse Input Voltage	–21 V

* The SNAP-IDC5Q supports an encoder input frequency of 25 kHz. However, legacy I/O brains have limited quadrature counting capability. The following limits apply to them:
2.5 kHz for SNAP-B3000-ENET brains
4 kHz for SNAP-UP1-ADS brains
5 kHz for other legacy brains with high-speed counting

See tables on the following two pages for more information.

Part Number

Part	Description
SNAP-IDC5Q	SNAP Two-Axis Quadrature Position Input

SNAP Quadrature Input Module

Using the SNAP-IDC5Q with SNAP PAC I/O Processors (with High-speed Counting)

Processor part numbers:

- SNAP-PAC-R1
- SNAP-PAC-R1-FM
- SNAP-PAC-R1-W
- SNAP-PAC-EB1
- SNAP-PAC-EB1-FM
- SNAP-PAC-EB1-W
- SNAP-PAC-SB1

To determine maximum RPM, use the following chart or the equation below:

$$\text{Maximum Encoder RPM} = \frac{1,500,000}{\text{Encoder Pulses per Revolution}}$$

SNAP PAC I/O Processors	
Encoder PPR	Maximum RPM
1	1,500,000
10	150,000
12	125,000
60	25,000
100	15,000
120	12,500
200	7500
240	6250
256	5859
300	5000
360	4167
400	3750
500	3000
600	2500
720	2083
900	1667
1000	1500
1024	1465
2000	750

Using the SNAP-IDC5Q with a SNAP Ultimate I/O Processor

Processor part number:

- SNAP-UP1-ADS

(Legacy product) To determine maximum RPM, use the following chart or the equation below:

$$\text{Maximum Encoder RPM} = \frac{240,000}{\text{Encoder Pulses per Revolution}}$$

SNAP-UP1-ADS	
Encoder PPR	Maximum RPM
1	240,000
10	24,000
12	20,000
60	4000
100	2400
120	2000
200	1200
240	1000
256	938
300	800
360	667
400	600
500	480
600	400
720	333
900	267
1000	240
1024	234
2000	120

SNAP Quadrature Input Module

Using the SNAP-IDC5Q with Legacy Ethernet Brains

Processor part numbers:

- SNAP-B3000-ENET
- SNAP-ENET-RTC

To determine maximum RPM, use the following chart or the equation below:

$$\text{Maximum Encoder RPM} = \frac{150,000}{\text{Encoder Pulses per Revolution}}$$

Legacy SNAP Ethernet Brains	
Encoder PPR	Maximum RPM
1	150,000
10	15,000
12	12,500
60	2500
100	1500
120	1250
200	750
240	625
256	586
300	500
360	417
400	375
500	300
600	250
720	208
900	167
1000	150
1024	146
2000	75

Using the SNAP-IDC5Q with Legacy Serial-based Brains

Processor part numbers:

- B3000
- B3000-B
- B3000-HA (obsolete)

To determine maximum RPM, use the following chart or the equation below:

$$\text{Maximum Encoder RPM} = \frac{300,000}{\text{Encoder Pulses per Revolution}}$$

B3000, B3000-B, and B3000-HA Brains	
Encoder PPR	Maximum RPM
1	300,000
10	30,000
12	25,000
60	5000
100	3000
120	2500
200	1500
240	1250
256	1172
300	1000
360	833
400	750
500	600
600	500
720	417
900	333
1000	300
1024	293
2000	150

SNAP Quadrature Input Module

Connection Diagrams

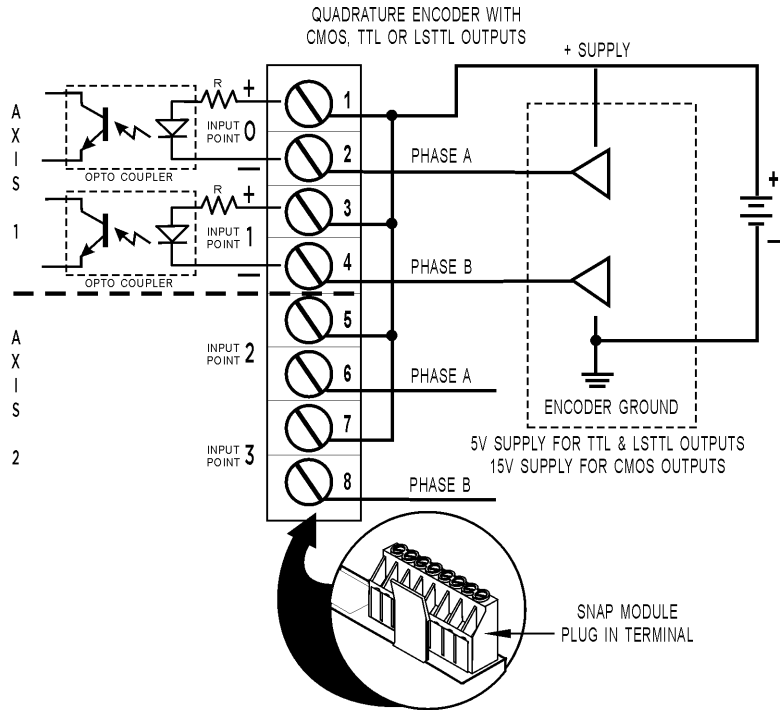

ALL INPUTS ARE ISOLATED FROM EACH OTHER AND DO NOT SHARE ANY COMMON CONNECTIONS INTERNALLY.

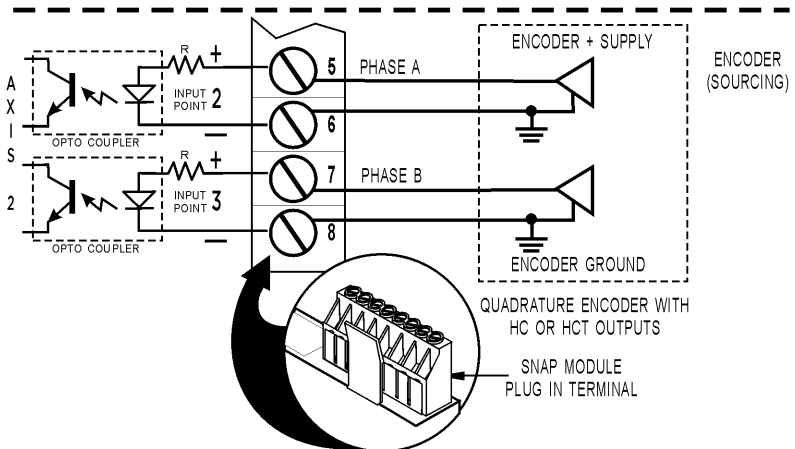
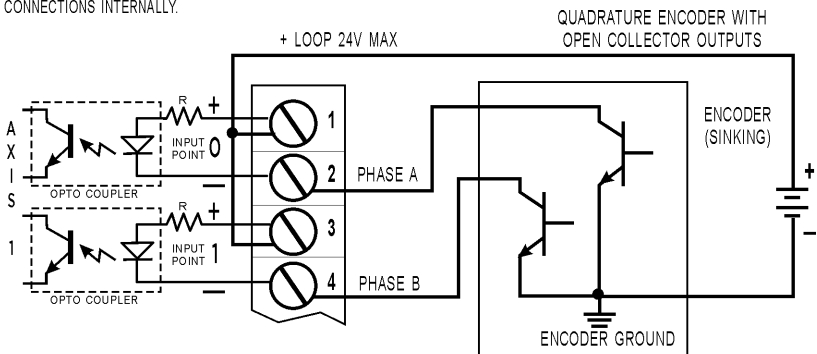

ALL INPUTS ARE ISOLATED FROM EACH OTHER AND DO NOT SHARE ANY COMMON CONNECTIONS INTERNALLY.

More About Opto 22

Products

Opto 22 develops and manufactures reliable, flexible, easy-to-use hardware and software products for industrial automation, remote monitoring, and data acquisition applications.

SNAP PAC System

Designed to simplify the typically complex process of understanding, selecting, buying, and applying an automation system, the SNAP PAC System consists of four integrated components:

- SNAP PAC controllers
- PAC Project™ Software Suite
- SNAP PAC brains
- SNAP I/O™

SNAP PAC Controllers

Programmable automation controllers (PACs) are multifunctional, multidomain, modular controllers based on open standards and providing an integrated development environment.

Opto 22 has been manufacturing PACs for many years. The latest models include the standalone SNAP PAC S-series and the rack-mounted SNAP PAC R-series. Both handle a wide range of digital, analog, and serial functions and are equally suited to data collection, remote monitoring, process control, and discrete and hybrid manufacturing.

SNAP PACs are based on open Ethernet and Internet Protocol (IP) standards, so you can build or extend a system without the expense and limitations of proprietary networks and protocols.

PAC Project Software Suite

Opto 22's PAC Project Software Suite provides full-featured and cost-effective control programming, HMI (human machine interface) development and runtime, OPC server, and database connectivity software to power your SNAP PAC System.

These fully integrated software applications share a single tagname database, so the data points you configure in PAC Control™ are immediately available for use in PAC Display™, OptoOPCServer™, and OptoDataLink™. Commands are in plain English; variables and I/O point names are fully descriptive.

PAC Project Basic offers control and HMI tools and is free for download on our website, www.opto22.com. PAC Project Professional, available for separate purchase, adds OptoOPCServer, OptoDataLink, options for Ethernet link redundancy or segmented networking, and support for legacy Opto 22 serial *mistic*™ I/O units.

SNAP PAC Brains

While SNAP PAC controllers provide central control and data distribution, SNAP PAC brains provide distributed intelligence for I/O processing and communications. Brains offer analog, digital, and serial functions, including thermocouple linearization; PID loop control; and optional high-speed digital counting (up to 20 kHz), quadrature counting, TPO, and pulse generation and measurement.

SNAP I/O

I/O provides the local connection to sensors and equipment. Opto 22 SNAP I/O offers 1 to 32 points of reliable I/O per module, depending on the type of module and your needs. Analog, digital, serial, and special-purpose modules are all mixed on the same mounting rack and controlled by the same processor (SNAP PAC brain or rack-mounted controller).

Quality

Founded in 1974 and with over 85 million devices sold, Opto 22 has established a worldwide reputation for high-quality products. All are made in the U.S.A. at our manufacturing facility in Temecula, California. Because we do no statistical testing and each part is tested twice before leaving our factory, we can guarantee most solid-state relays and optically isolated I/O modules for life.

Free Product Support

Opto 22's Product Support Group offers free, comprehensive technical support for Opto 22 products. Our staff of support engineers represents decades of training and experience. Product support is available in English and Spanish, by phone or email, Monday through Friday, 7 a.m. to 5 p.m. PST.

Free Customer Training

Hands-on training classes for the SNAP PAC System are offered at our headquarters in Temecula, California. Each student has his or her own learning station; classes are limited to nine students. Registration for the free training class is on a first-come, first-served basis. See our website, www.opto22.com, for more information or email training@opto22.com.

Purchasing Opto 22 Products

Opto 22 products are sold directly and through a worldwide network of distributors, partners, and system integrators. For more information, contact Opto 22 headquarters at 800-321-6786 or 951-695-3000, or visit our website at www.opto22.com.

www.opto22.com